

ANL A,R6	ANL A,25H
ANL A,@R1	ANL A,#03H
ANL 25H,A	
ANL C,ACC.5 ;bit operation	
ANL C,/ACC.5 ;use complement of bit	

Figure 9.27: Logical AND Instructions

ORL A,R6	ORL A,25H
ORL A,@R1	ORL A,#03H
ORL 25H,A	
ORL C,ACC.5 ;bit operation	
ORL C,/ACC.5 ;use complement of bit	

Figure 9.28: Logical OR Instructions

XRL A,R6	XRL A,25H
XRL A,@R1	XRL A,#03H
XRL 25H,A	

Figure 9.29: Logical XOR Instructions

Inversion Inverting (complementing) as shown in Figure 9.26 is the simplest logic; every 1 becomes a 0 and vice versa. One byte comes in, and the output is the opposite of the input—the *ones complement* of the incoming number. Incidentally, you can also invert using the exclusive OR (*XRL*) command with *FFH*. That is discussed later with the logical instructions.

Logical AND Instructions Figure 9.27 shows logical ANDing instructions that put a 1 in a bit position only if *both* incoming bits at that position are 1. Notice that this instruction does *not* necessarily leave the result in the accumulator!

Logical OR Instructions Figure 9.28 shows logical ORing instructions that put a 1 in a position if *either* incoming bit is 1.

Exclusive OR Instructions Figure 9.29 shows the logical exclusive ORing instructions that put a 1 in a bit position if and only if one of the two input bits is 1; if both bits are high, it puts a 0. Note that *XRL A, #FFH* will invert the accumulator.

Rotate Instructions The effects of these four instructions (Figure 9.31) can be seen in Figure 9.30. The byte is shifted by one place left (toward *msb*) or right (toward *lsb*). If the carry is included (*RRC* or *RLC*), then the end bit goes into the carry, and the carry goes around into the other end..

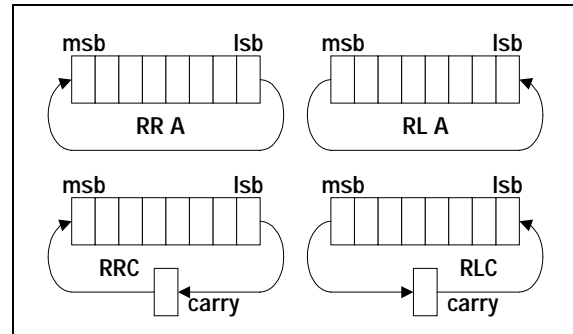

Figure 9.30: Effect of 4 Rotate Instructions

RL A
RR A
RRC A
RLC A

Figure 9.31: Rotate Instructions

CPL C ;the carry bit
CPL P3.5

Figure 9.32: Bit Invert Instructions

CLR A
CLR C ;the carry bit
CLR ACC.7
CLR P1.5

Figure 9.33: Bit & Byte Clear Instructions

SETB C
SETB 20.3
SETB ACC.7

Figure 9.34: Bit Set Instructions

Bit Operations

Bit Complement Figure 9.32 shows the bit complement instructions that put a 0 for a 1 and a 1 for a 0. *CPL A* was already shown as the byte invert instruction.

Clear Instructions Figure 9.33 shows the instructions that clear the byte or bit involved. The bit operations work on the 128 bits in the 20-2F area as well as the bit addressable SFRs, including the accumulator and the on-chip ports.

Bit Set Instructions Figure 9.34 shows the instructions that make the indicated bit a 1.